

# WIRELESS CHARGING ALARM CLOCK

8086170

Instruction Manual

## INCLUDED

- Wireless charging alarm clock
- Power adapter
- 1 CR2032 battery
- Instruction manual

## COMPONENT IDENTIFICATION

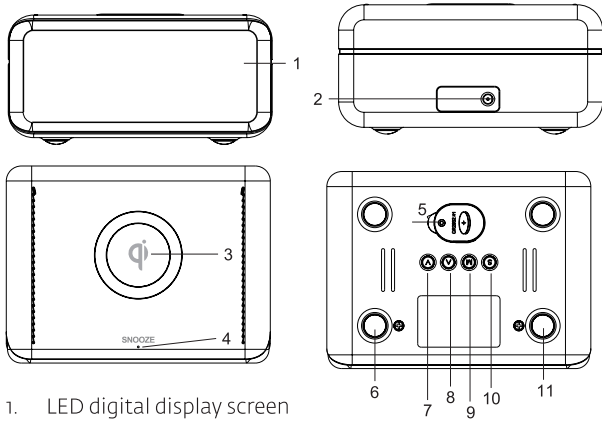

1. LED digital display screen
2. DC adapter port
3. Wireless charging pad
4. Wireless charging LED indicator
5. Battery cover
6. Snooze button/Alarm
7. Arrow up
8. Arrow down
9. Mode button
10. Settings button
11. Snooze button/Alarm

## FEATURES

- 5W Qi wireless charging
- Alarm clock with snooze
- LCD screen with 4 levels of brightness

## OPERATING INSTRUCTIONS

### WIRELESS CHARGING

1. Place your Qi-enabled smartphone in the centre of the charging pad on the top of the alarm clock.



2. The LED indicator will be red when your phone is charging. It will turn green when your phone is fully charged\*.

**NOTE:** If the LED indicator is flashing red, the charger has encountered an error. Please check the device to make sure there aren't any metal objects on the wireless charging pad.

\*Not all phones will send a fully-charged signal to the wireless charger—the light will not turn green.

## BRIGHTNESS ADJUSTMENT

1. Plug in the included power adapter.
2. Press either front corner to cycle through the 4 levels of brightness. It will cycle through high, middle, low and OFF.



## SET THE TIME

1. Press "S" to enter the time setting function.
2. Touch "S" to scroll through hour, minute, year, month and day.
3. Press "▲" or "▼" to adjust the time. Press and hold the button for 3 seconds to scroll through quickly.
3. Press "S" to save settings and exit. Alternately, Press "M" to exit settings and return to time.

**NOTE:** In display mode press ▲ to change between 12 hour and 24 hour.

## SETTING THE ALARM AND SNOOZE

1. Press "M" to access alarm settings.
2. Press "S" to scroll through hour, minute and snooze time.
3. Press "▲" or "▼" to adjust the settings (press and hold the button for 3 seconds to scroll through quickly).
4. Press "M" to confirm the settings and exit.

## TURN ALARM ON/OFF

1. In clock mode, press either of the front corners (built-in button) for 1.5 seconds to turn the alarm ON or OFF.
2. When the alarm sounds, press either of the front corners to snooze it. The snooze icon will turn ON. If you do not turn the alarm OFF or press snooze, it will sound for 1 minute then silence automatically.
3. Press and hold either of the front corners while snoozing, the snooze and alarm will turn OFF and the snooze icon will disappear.

## SPECIFICATIONS

Adapter Output: 12V/1A

Wireless Output: 5V/1A

## WARNING

- **DO NOT** alter or disassemble this device to avoid an electrical shock
- **DO NOT** place this device on an unstable surface
- **DO NOT** expose this device to extreme humidity or temperatures
- **DO NOT** place metal or magnetic objects on the wireless charger (ID card, bank card, key cards etc.)
- **DOES NOT** support wireless fast charge
- Keep out of reach of children

## CAN RSS-216/CNR-216 IC:255A-8086170

This device contains licence-exempt transmitter(s)/receiver(s) that comply with Innovation, Science and Economic Development Canada's licence-exempt RSS(s). Operation is subject to the following two conditions: (1) This device may not cause interference. (2) This device must accept any interference, including interference that may cause undesired operation of the device.

## RF EXPOSURE INFORMATION:

This equipment complies with IC RSS-216 radiation exposure limits set forth for an uncontrolled environment. This equipment should be installed and operated with minimum distance 10cm between the radiator and your body.